

RCW, RCF

Технические характеристики

По вопросам продаж и поддержки обращайтесь:

Алматы (7273)495-231	Казань (843)206-01-48	Новокузнецк (3843)20-46-81	Смоленск (4812)29-41-54
Архангельск (8182)63-90-72	Калининград (4012)72-03-81	Новосибирск (383)227-86-73	Сочи (862)225-72-31
Астрахань (8512)99-46-04	Калуга (4842)92-23-67	Омск (3812)21-46-40	Ставрополь (8652)20-65-13
Барнаул (3852)73-04-60	Кемерово (3842)65-04-62	Орел (4862)44-53-42	Сургут (3462)77-98-35
Белгород (4722)40-23-64	Киров (8332)68-02-04	Оренбург (3532)37-68-04	Тверь (4822)63-31-35
Брянск (4832)59-03-52	Краснодар (861)203-40-90	Пенза (8412)22-31-16	Томск (3822)98-41-53
Владивосток (423)249-28-31	Красноярск (391)204-63-61	Пермь (342)205-81-47	Тула (4872)74-02-29
Волгоград (844)278-03-48	Курск (4712)77-13-04	Ростов-на-Дону (863)308-18-15	Тюмень (3452)66-21-18
Вологда (8172)26-41-59	Липецк (4742)52-20-81	Рязань (4912)46-61-64	Ульяновск (8422)24-23-59
Воронеж (473)204-51-73	Магнитогорск (3519)55-03-13	Самара (846)206-03-16	Уфа (347)229-48-12
Екатеринбург (343)384-55-89	Москва (495)268-04-70	Санкт-Петербург (812)309-46-40	Хабаровск (4212)92-98-04
Иваново (4932)77-34-06	Мурманск (8152)59-64-93	Саратов (845)249-38-78	Челябинск (351)202-03-61
Ижевск (3412)26-03-58	Набережные Челны (8552)20-53-41	Севастополь (8692)22-31-93	Череповец (8202)49-02-64
Иркутск (395)279-98-46	Нижний Новгород (831)429-08-12	Симферополь (3652)67-13-56	Ярославль (4852)69-52-93
Россия (495)268-04-70	Киргизия (996)312-96-26-47	Казахстан (7172)727-132	

Контроллер соотношения

Контроллер соотношения является частью системы дозирования пенопластового бака. Обеспечивает точную дозировку пенообразователя в водопроводную линию, создавая пенный раствор высокого качества. Контроллер соотношения доступен в конструкции из нержавеющей стали и бронзы. Он охватывает широкий диапазон потоков. Пожалуйста, обратитесь к каталогу продукции HD263 для получения дополнительной информации о сертификатах и диапазоне расхода.

- › Межфланцевое или фланцевое соединение
- › Размеры 65, 80, 100, 150 и 200 мм (2,5 дюйма, 3 дюйма, 4 дюйма, 6 дюймов и 8 дюймов) с расходом от 100 до 18500 л/мин (от 26 до 4887 галлонов в минуту)
- › Используется с баком-дозатором или встроенным дозатором уравнивающего давления для переменного расхода
- › Обеспечивает индукцию 3% или 6%, просто меняя отверстие
- › Рабочее давление: Максимум от 3 до 14 бар (от 44 до 200 фунтов на кв. дюйм)
- › Внесен в список UL и одобрен FM (подробности см. в каталоге продукции HD263)



TECHNICAL DATA

MODEL	Stainless Steel Construction: RCW-S, RCW-SM, RCF-S, RCF-SM Bronze Construction: RCW-B, RCW-BM RCF-B, RCF-BM
SIZE	65, 80, 100, 150 & 200 NB
MAXIMUM SERVICE PRESSURE	14 bar (200 psi) 12.3 bar (175 psi) for UL & FM
FACTORY HYDRO-STATIC TEST PRESSURE	25 bar (350 psi)
MOUNTING	Between the flanges ANSI B16.5 - 150#
APPROVAL	UL Listed and FM Approved
FINISH	Red RAL 3001 or Natural Finish
ORDERING INFORMATION	Specify a) Model & Size b) Minimum and Maximum Pressure and flow rate c) Induction Percentage d) Type of Foam Concentrate used

DESCRIPTION

Ratio Controller is used for proportioning foam concentrate into the water supply with a wide range of flow and pressure. The Ratio Controller is also used with Bladder Tank Proportioning System, Inline Balance Proportioning System and Skid Mounted Pump Balance Proportioning System.

SPECIFICATION

The Ratio Controller works on venturi principle. As the water flow passes through nozzle at the inlet of ratio controller, a low-pressure area is created between inlet nozzle and the down stream section called diffuser. This low-pressure area causes the foam concentrate to flow through a metering orifice at the concentrate inlet and into the low-pressure area.

As the system demand varies, the water jet through Ratio Controller increases or decreases, which in turn varies the pressure at the low-pressure area of the Ratio Controller. This affects the corresponding pressure across the foam concentrate-metering orifice. The system requires same pressure of water and concentrate in order to balance the proportioning system.

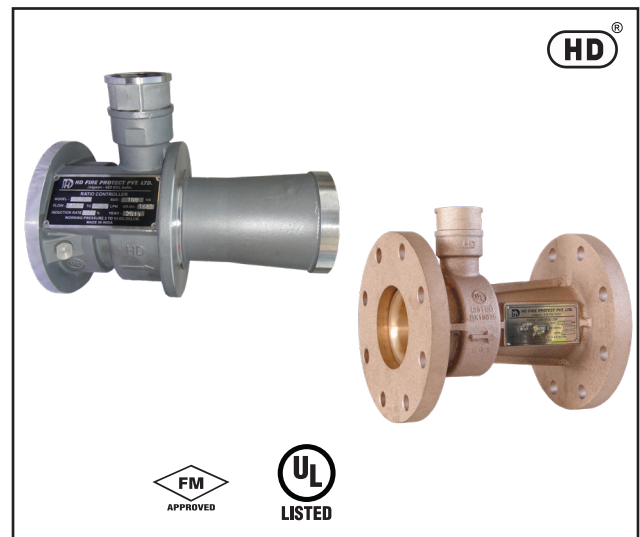

INSTALLATION

Ratio Controller Model RCW is wafer style to be mounted in SCH40 pipe between two flanges while Model RCF has flanged end connection. Flow direction arrow is marked on the Ratio Controller.

NOTE

- 1) A minimum of five pipe diameter of straight unobstructed pipe is required at upstream and downstream of each ratio controller.
- 2) Ratio Controller shall be installed between two ANSI 150# flanges with raised face or flat face. Gaskets, studs & flanges shall be provided by the installer.
- 3) Provision shall be made in piping for removal of Ratio Controller.
- 4) The pipes on upstream & downstream side of the Ratio Controller must be adequately supported and no strain shall be imposed on Ratio Controller.
- 5) Ratio Controller is UL Listed/ FM Approved with HD Bladder Tank, Refer to specific UL Listing / FM Approval data for more information.
- 6) Ratio Controller is UL Listed for 2.1 to 12 bar pressure.
- 7) For Flow data, when used with Inline Balance pressure proportioner, contact HD Fire Sales.

RATIO CONTROLLER (WAFER STYLE - RCW SERIES)

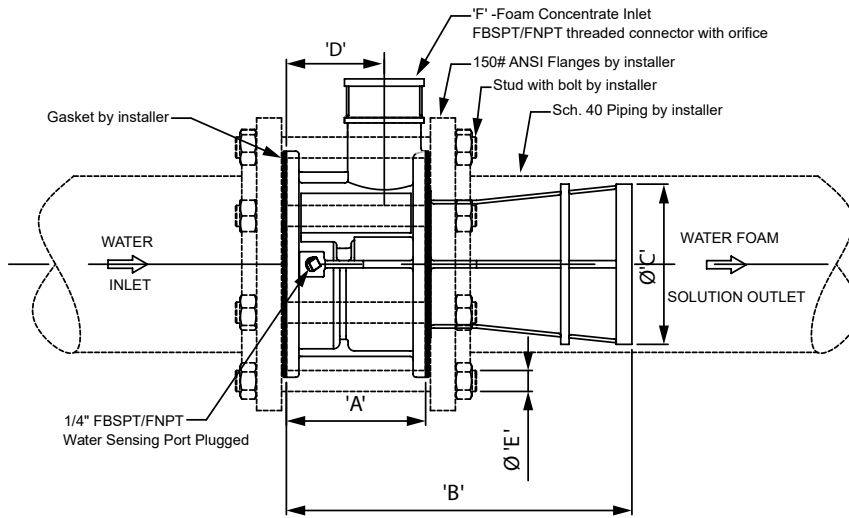

DIMENSIONS

Size	Approximate Dimensions (in mm)					
	'A'	'B'	Ø 'C'	'D'	Ø 'E'	'F'
2½"	80	190	Ø61.7	55	M16 x 170 LONG	1" BSPT (F)/NPT (F)
3"	107.5	190	Ø76	82.5	M16 x 200 LONG	1½" BSPT (F)/NPT (F)
4"	126	266	Ø101	90	M16 x 220 LONG	1½" BSPT (F)/NPT (F)
6"	133	330	Ø152	93.5	M20 x 230 LONG	2" BSPT (F)/NPT (F)
8"	130	340	Ø200	80	M20 X 240 LONG	2" BSPT (F)/NPT (F)

RATIO CONTROLLER (FLANGE STYLE - RCF SERIES)

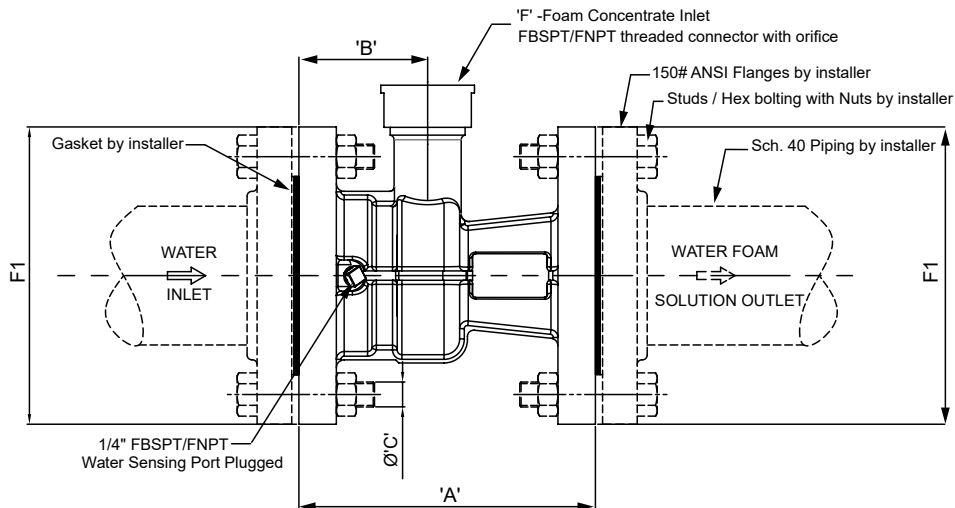

Dimensions of Inlet / Outlet Flanges (F1) is as per ANSI B16.5 #150

DIMENSIONS

Size	Approximate Dimensions (in mm)			
	'A'	'B'	Ø 'C'	'F'
2½"	190	55	M16	1" BSPT (F)/NPT (F)
3"	190	82.5	M16	1½" BSPT (F)/NPT (F)
4"	266	90	M16	1½" BSPT (F)/NPT (F)
6"	330	93.5	M20	2" BSPT (F)/NPT (F)
8"	340	80	M20	2" BSPT (F)/NPT (F)

UL LISTED RATIO CONTROLLER FLOW RANGE (LPM)

Size	Model		UL Listed	
	Wafer Style	Flange Style	AFFF 3%	AR-AFFF 3X3%
65 NB	RCW-B, RCW-S	RCF-B, RCF-S	100 TO 1550	421 TO 1460
	RCW-BM, RCW-SM	RCF-BM, RCF-SM	-----	160 TO 582
80 NB	RCW-B, RCW-S	RCF-B, RCF-S	260 TO 3000	787 TO 3060
	RCW-BM, RCW-SM	RCF-BM, RCF-SM	-----	-----
100 NB	RCW-B, RCW-S	RCF-B, RCF-S	650 TO 6000	1140 TO 6060
150 NB	RCW-B, RCW-S	RCF-B, RCF-S	1200 TO 12000	-----
	RCW-BM, RCW-SM	RCF-BM, RCF-SM	-----	2370 TO 12210
200 NB	RCW-B, RCW-S	RCF-B, RCF-S	2750 TO 17860	2320 TO 17500

FM APPROVED RATIO CONTROLLER FLOW RANGE (LPM)

Size	Model		FM Approved	
	Wafer Style	Flange Style	AFFF 3%	AR-AFFF 3X3%
65 NB	RCW-B, RCW-S	RCF-B, RCF-S	102 TO 1590	500 TO 1030
	RCW-BM, RCW-SM	RCF-BM, RCF-SM	-----	165 TO 528
80 NB	RCW-B, RCW-S	RCF-B, RCF-S	290 TO 2990	-----
	RCW-BM, RCW-SM	RCF-BM, RCF-SM	-----	820 TO 3080
100 NB	RCW-B, RCW-S	RCF-B, RCF-S	600 TO 6050	1810 TO 6140
150 NB	RCW-B, RCW-S	RCF-B, RCF-S	1200 TO 11460	5000 TO 12300
	RCW-BM, RCW-SM	RCF-BM, RCF-SM	-----	-----
200 NB	RCW-B, RCW-S	RCF-B, RCF-S	-----	-----

По вопросам продаж и поддержки обращайтесь:

Алматы (7273)495-231	Казань (843)206-01-48	Новокузнецк (3843)20-46-81	Смоленск (4812)29-41-54
Архангельск (8182)63-90-72	Калининград (4012)72-03-81	Новосибирск (383)227-86-73	Сочи (862)225-72-31
Астрахань (8512)99-46-04	Калуга (4842)92-23-67	Омск (3812)21-46-40	Ставрополь (8652)20-65-13
Барнаул (3852)73-04-60	Кемерово (3842)65-04-62	Орел (4862)44-53-42	Сургут (3462)77-98-35
Белгород (4722)40-23-64	Киров (8332)68-02-04	Оренбург (3532)37-68-04	Тверь (4822)63-31-35
Брянск (4832)59-03-52	Краснодар (861)203-40-90	Пенза (8412)22-31-16	Томск (3822)98-41-53
Владивосток (423)249-28-31	Красноярск (391)204-63-61	Пермь (342)205-81-47	Тула (4872)74-02-29
Волгоград (844)278-03-48	Курск (4712)77-13-04	Ростов-на-Дону (863)308-18-15	Тюмень (3452)66-21-18
Вологда (8172)26-41-59	Липецк (4742)52-20-81	Рязань (4912)46-61-64	Ульяновск (8422)24-23-59
Воронеж (473)204-51-73	Магнитогорск (3519)55-03-13	Самара (846)206-03-16	Уфа (347)229-48-12
Екатеринбург (343)384-55-89	Москва (495)268-04-70	Санкт-Петербург (812)309-46-40	Хабаровск (4212)92-98-04
Иваново (4932)77-34-06	Мурманск (8152)59-64-93	Саратов (845)249-38-78	Челябинск (351)202-03-61
Ижевск (3412)26-03-58	Набережные Челны (8552)20-53-41	Севастополь (8692)22-31-93	Череповец (8202)49-02-64
Иркутск (395)279-98-46	Нижний Новгород (831)429-08-12	Симферополь (3652)67-13-56	Ярославль (4852)69-52-93
Россия (495)268-04-70	Киргизия (996)312-96-26-47	Казахстан (7172)727-132	